

UNIROLL

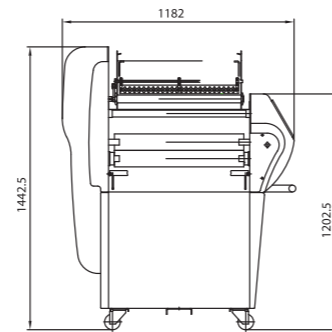

MAGNUM

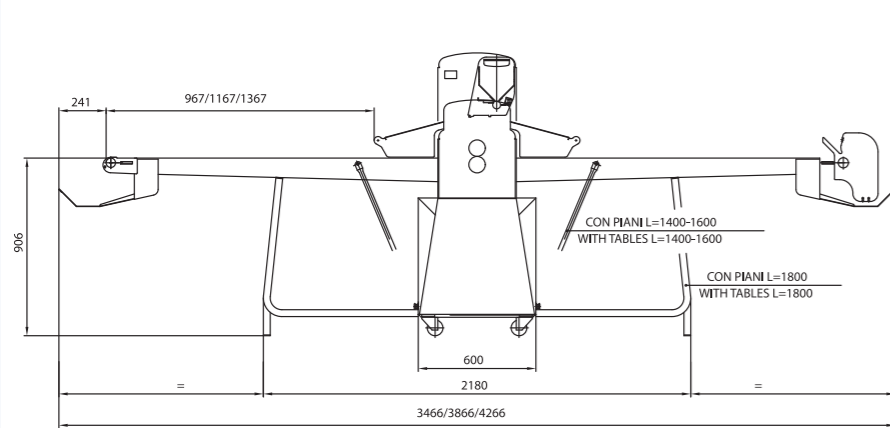
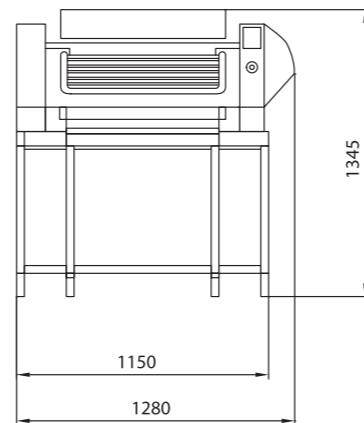
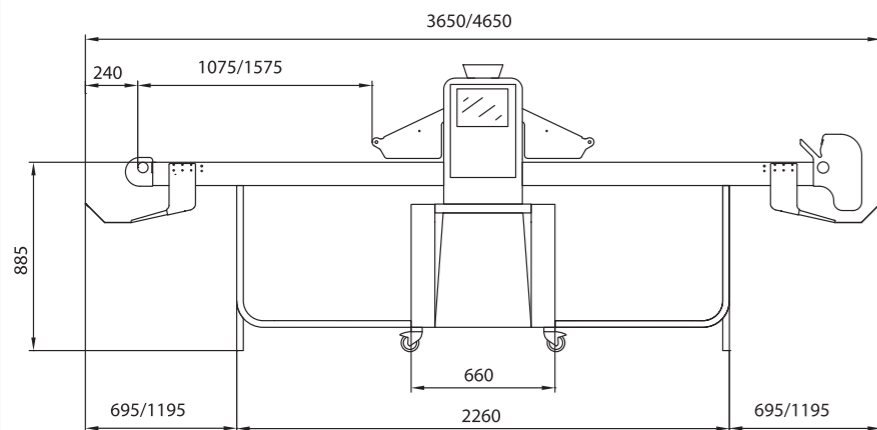

(Tutti i dati tecnici qui riportati possono essere variati dal costruttore mantenendo inalterata la funzionalità dell'impianto)

(All the above mentioned technical data can be modified accordingly without changing the functionality of the unit)



ALBA & Teknoservice s.r.l.
Via delle Industrie, 16/B 35010 VILLAFRANCA PAD. (PD) - ITALY
Tel. +39 049.9070380 - Fax +39 049.9074042
www.albaequipment.it - e-mail: info@teknoservice.com

Rivenditore

Q&BGRAFICHE s.r.l 0109

I believe in!



BAKERY AND PASTRY EQUIPMENT

SFOGLIATRICI AUTOMATICHE

AUTOMATIC SHEETERS



SFOGLIATRICE AUTOMATICA AUTOMATIC SHEETER **EASY**



Sfogliatrice automatica facilmente programmabile da touch screen 4".
Dotata di 100 programmi con un massimo di 35 passate per programma.



Automatic sheeter easily programmable by touch screen 4".
It has 100 programs with a maximum of 35 passes through the rollers for each program.

SFOGLIATRICE AUTOMATICA AUTOMATIC SHEETER **UNIROLL**



Sfogliatrice automatica facilmente programmabile da touch screen 5,7".
Dotata di 100 programmi con un massimo di 35 passate per programma.
Adatta a tutti i tipi di pasta, con possibilità di lavoro con ciclo automatico o manuale.
Equipaggiata con sfarinatore automatico programmabile e avvolgitore automatico.



Automatic sheeter easily programmable by touch screen 5,7".
It has 100 programs with a maximum of 35 passes through the rollers for each program.
Suitable for all types of dough, with possibility of working by automatic or manual operating cycle.
Equipped with automatic programmable flour duster and automatic unit for dough rolling.

SFOGLIATRICE AUTOMATICA AUTOMATIC SHEETER **MAGNUM**



Sfogliatrice automatica di concezione industriale facilmente programmabile da touch screen 7,5".
Dotata di 100 programmi con un massimo di 35 passate per programma.
Adatta a tutti i tipi di pasta, con possibilità di lavoro con ciclo automatico o manuale.
Equipaggiata con sfarinatore automatico programmabile e avvolgitore automatico.



Automatic sheeter industrial-planned easily programmable by touch screen 7,5".
It has 100 programs with a maximum of 35 passes through the rollers for each program.
Suitable for all types of dough, with possibility of working by automatic or manual operating cycle.
Equipped with automatic programmable flour duster and automatic unit for dough rolling.

MODELLO MODEL	DIMENSIONE TAPPETI (mm) BELT DIMENSION	DIAMETRO CILINDRI (mm) CYLINDERS DIAMETER	LUNGHEZZA CILINDRI (mm) CYLINDERS LENGHT	APERTURA CILINDRI (mm) CYLINDERS OPENING	POTENZA INSTALLATA (Kw) INSTALLED POWER	VELOCITA' TAPPETI USCITA SPEED ON THE EXIT BELT	NUMERO PROGRAMMI NUMBER OF PROGRAMS
EASY 1400	650 x 1400	84	650	0 - 60	2	10 - 60 m/min	100
EASY 1600	650 x 1600	84	650	0 - 60	2	10 - 60 m/min	100
EASY 1800	650 x 1800	84	650	0 - 60	2	10 - 60 m/min	100
UNIROLL 1400	650 x 1400	84	650	0 - 60	2	10 - 60 m/min	100
UNIROLL 1600	650 x 1600	84	650	0 - 60	2	10 - 60 m/min	100
UNIROLL 1800	650 x 1800	84	650	0 - 60	2	10 - 60 m/min	100
MAGNUM 1500	700 x 1500	71	685	0 - 48	2	10 - 60 m/min	100
MAGNUM 2000	700 x 2000	71	685	0 - 48	2	10 - 60 m/min	100